

RE60 FREE WEIGHT SERIES**RE6032 - GLUTE/HAM DEVELOPER BENCH****PRODUCT OVERVIEW**

The RE6032 is a multifunctional professional machine designed for posterior chain development, targeting the glutes, hamstrings, and lower back. Built with a solid structure and refined craftsmanship, it is ideal for commercial gyms and high-end training spaces.

Its flat hip extension design allows for efficient use of both bodyweight and external load, increasing training intensity and muscular engagement. The front half-round high-resilience thigh pad provides comfortable hip support while maintaining full flexion and extension range, ensuring smooth motion and enhanced training quality.

Extended side handles are ergonomically positioned to avoid interference during exercise while providing reliable assistance for mounting and dismounting. Dual rear ankle pads feature 3 adjustable distances to accommodate users with varying leg sizes, while the footplate offers 8 adjustable positions for different heights. Anti-slip foot platforms ensure safety during use. Resistance band pegs on both sides allow users to add progressive resistance at the end range of motion, increasing muscle tension and training effectiveness.

SPECIFICATIONS & KEY FEATURES

Specifications

Dimension:	1757*1303*1335mm
Total Weight:	92.5kg

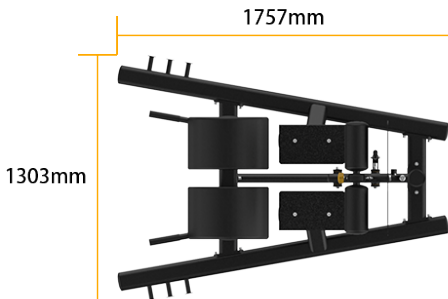
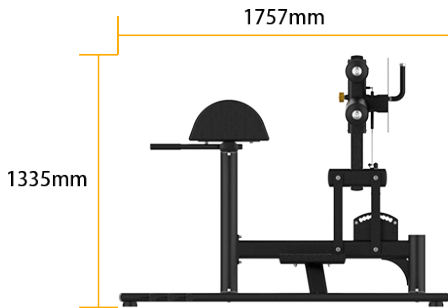
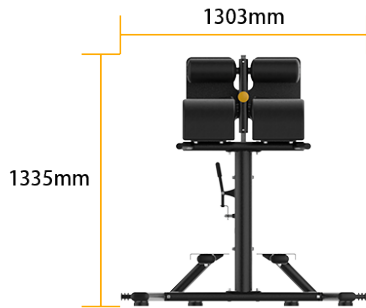

Product Features



Comfort Support System

The high-resilience half-round thigh pad combined with extended handles ensures stable support, training comfort, and safe mounting/dismounting.



Adjustable Foot Support System

Dual ankle pads with 3 distance settings and an 8-position adjustable footplate adapt to users of different builds, enhancing comfort, stability, and safety.



Anti-Slip Access Platform

Durable, non-slip foot platforms improve safety and provide stable support when mounting or adjusting position.



Resistance Band Pegs

Dual resistance band hooks increase end-range muscle activation and resistance, maximizing training intensity and output.